

# *TripMate™ 2012*

Magnetic Shut-Off Switch

## User Guide



Plunger Arrival Sensor

Intrinsically Safe for use in  
Class 1 Division 1 Group C and Group D  
Hazardous Locations

# TripMate 2012 Components

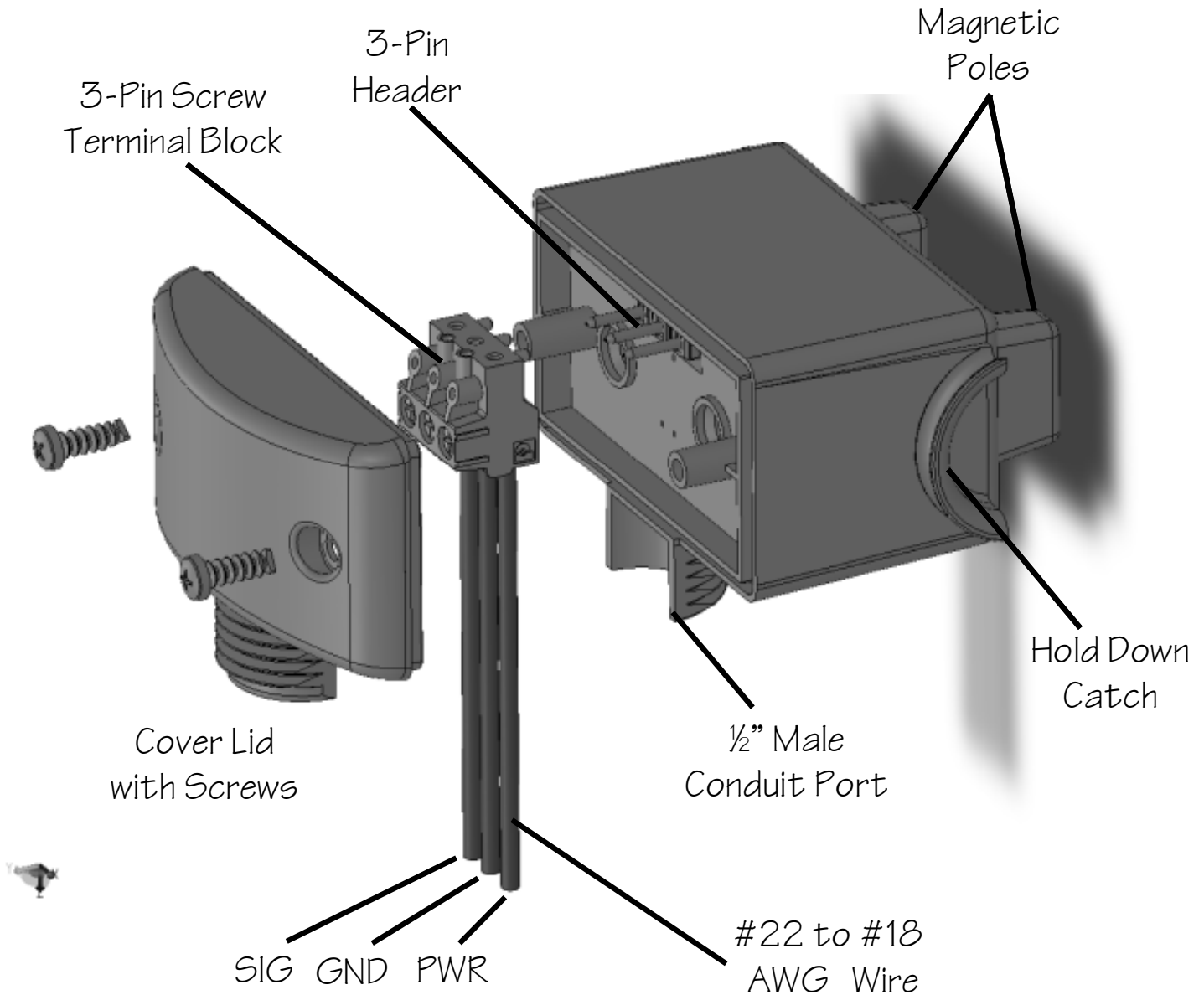

The TripMate 2012's standard configuration includes a removable, 3-Pin screw terminal block, an integral 1/2" male conduit cable port and a screw down cover lid. Sensor hookup accommodates both 2-Wire and 3-Wire operation using #22 to #18 AWG wire.

## 2-Wire Hookup

The standard 2-Wire option provides hookup to the TripMate 2012 without the need to connect an external power source. To use the 2-Wire option, simply hookup the signal wire (Input) to the "SIG" terminal and the common or negative wire (-) to the "GND" connection. The TripMate 2012's internal battery will provide 7+ years of operation.



## 3-Wire Hookup

The 3-Wire option allows the TripMate 2012 to be powered from an external source. To use the 3-Wire option, hookup the signal (Input) to the "SIG" terminal, the common or negative (-) to the "GND" terminal and the external power source's positive (+) to the "PWR" terminal. No power will be drawn from the external power source until the TripMate 2012's internal battery discharges below a useable level. As the internal battery's voltage drops, the external power source will be used to supplement and maintain optimum performance.

# Conduit Cable Run

The conduit port allows the TripMate 2012 to be easily connected to a 1/2" conduit cable run. The TripMate's 1/2" male conduit port is an integral part of the molded enclosure. A "male-to-male" union and "IS cable seal" are available through OKC Products, Inc. to accommodate cable runs into and out of Class 1 Division 1 hazardous locations. Unions and cable seals are sold separately.

## TripMate Testing

The TripMate may be tested for proper operation using a Volt-Ohm Meter (VOM) set to the ohm or resistance measurement scale. The VOM's red (+) and black (--) leads are connected to the SIG and GND terminals, respectively.

A "no trigger" will read as an open circuit or infinite ohms. Triggering the TripMate by moving it on the wellhead pipe or passing a metal object close to the magnetic poles will read as a short circuit or zero ohms.

The TripMate trigger duration is a minimum of one (1) second. If the VOM does not show a change from the open circuit to a short circuit status when triggered, a problem may exist with the TripMate

# TripMate 2012 Installation

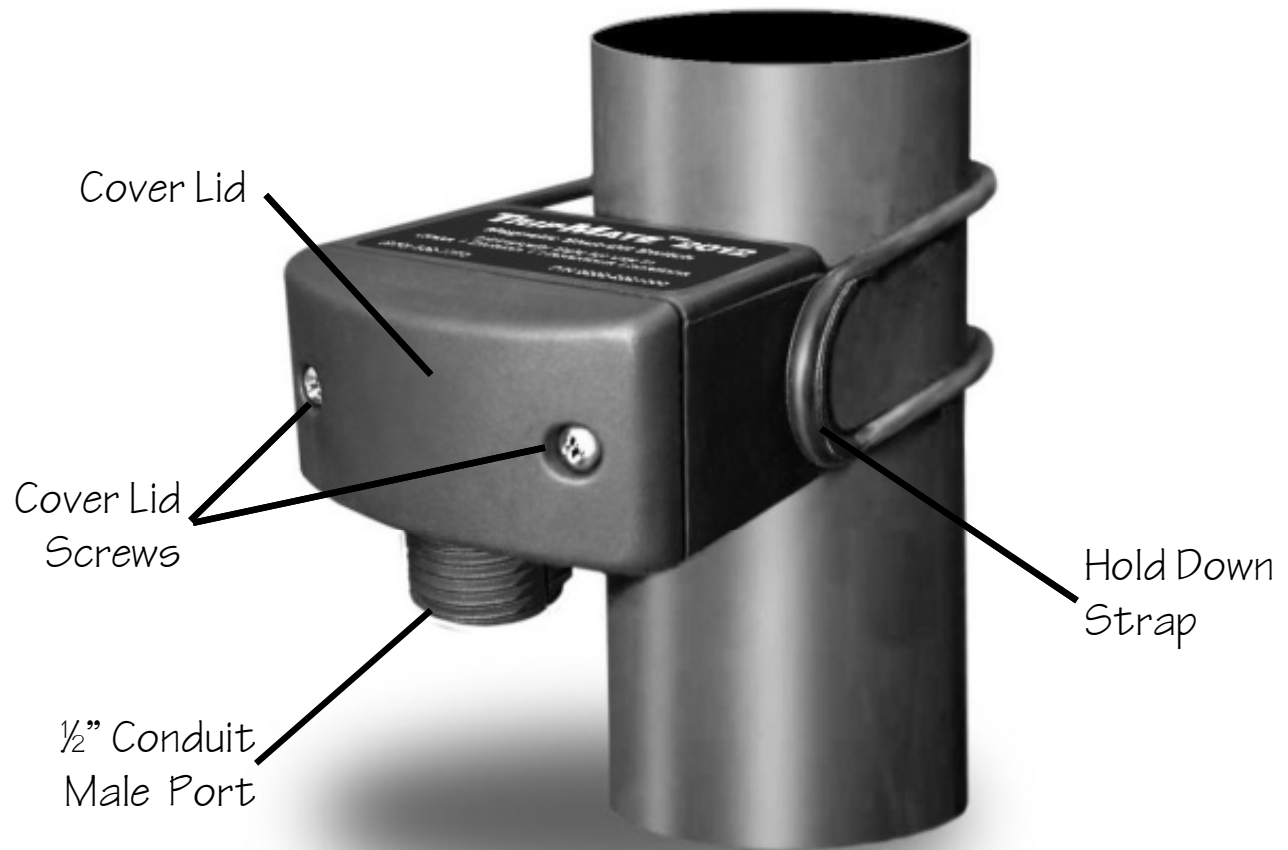

When installing the TripMate on a well head, care should be taken to ensure the magnetic poles do not sit on bumps that allow the sensor to rock or move relative to the mounting surface. Paint chips, rust spots, welding residue and pipe wrench claw marks provide pivot points for the TripMate to rock or wobble. Using a flat file to remove bumps or move the TripMate to a smoother pipe area is recommended. Use the O-ring hold down strap provided with the TripMate to hold the sensor in place.

# Mounting Methods

The mounting of any arrival sensor needs to accommodate simple, easy installation as well as meeting requirements for accurate plunger sensing. For best sensing results, install the TripMate on the well head at a location where the plunger passes the sensor and not where the plunger stops after arrival occurs.

The thickness of the metal the TripMate has to penetrate also makes a difference. The thinner the better – plunger arrival sensing is more reliable on the tubing below the lubricator. This also assures that the TripMate sees a clean, complete plunger arrival as the plunger passes the TripMate sensor.

## Intrinsic Safety Certification

The TripMate 2012 has been certified Intrinsically Safe for use in Class 1 Division 1, Group C and Group D hazardous locations. Installation must be in accordance with the National Electric Code® (NFPA 70, Article 504), the Canadian Electrical Code (C22.1), and ANSI/ISA-RP12.6.

See TripMate 2012 Drawing No. 9202-2022099 Rev. M Intrinsic Safety Control Drawing for connection to associated apparatus with entity parameters.

# Product Warranty Statement

**OKC Products, Inc.** (Warrantor), Berthoud, Colorado USA, warrants each TripMate 2012 (Product) to be free from defects in material and workmanship under normal use and service for a period of twelve (12) months from the original date of purchase from OKC Products, Inc. This warranty shall not apply to a Product that failed as a result of misuse, neglect, accident, abuse, mishandling, misapplication, alteration, or abnormal conditions of operations. In the event of a Product failure covered by this warranty, Warrantor will exchange returned Product with a new, unused Product, provided the Warrantor's examination discloses to its satisfaction that the Product was, indeed defective. With regard to Product returned within twelve (12) months of the original purchase date, the cost of said exchange Product will be at no charge in the USA, excluding transportation cost to and from OKC Products, Inc.

Return Product shipments must be "**Best Way Prepaid**". Ship the Product in its original container or in a suitable container that is rigid and of adequate size. Ship to:

OKC Products, Inc.  
585 N. 1st Street  
Berthoud, CO 80513  
Tel. 970-532-1773.

## Accessories

*Part Number*

*Item Description*

**2550-2242EPR** Rubber O-Ring Hold Down  
4" ID, 1/8" W Ethylene Propylene  
Fastens to hold down catch.

**4160-2022130** TripMate 2012 Cover Lid  
Molded Dark Grey Color.  
Without hold down screws.

**2802-4482375** Cover Lid #4-40 x 3/8" Screw  
Stainless Steel Phillips Pan Head.  
Plastite style 48-2 TFS.

**2169-0719322** Screw Terminal Block  
3-Station, #22 - #18 AWG wire.  
Removable from 3-Pin header.

**2802-0505240** 1/2" Alum. Conduit Union  
Killark Female 1-7/8" long.  
CSA C22.30 No 30. / UL 886



**6003-9493220** 1/2" Cable Seal Assembly  
3-Conductor #20 AWG wire.  
1-1/2 ft. entry and 6 ft. exit pigtails.

